

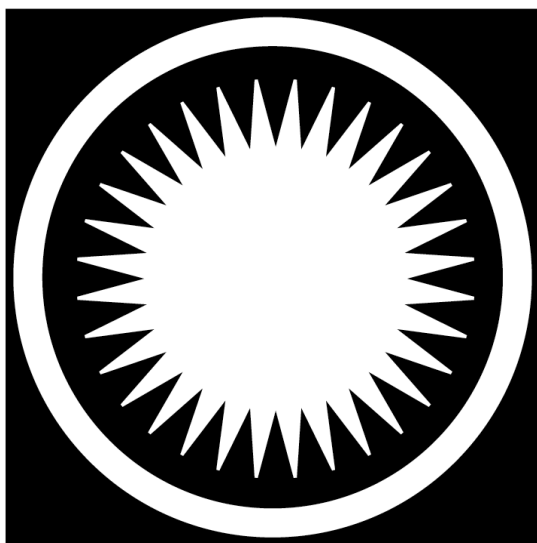

Operation and Installation Manual

Boiler Buffer **Hot Water Storage Tank**

Limited Warranty and Tank Replacement



GENERAL INFORMATION

PLEASE READ INSTRUCTIONS CAREFULLY BEFORE INSTALLING WATER HEATER

Vaughn Thermal Corporation (herein called the Company) intends that this BUFFER STORAGE TANK be used with a tankless coil boiler.

The Company specifically does not expressly or impliedly warrant the merchantability or the fitness for any particular purpose or the performance of the heater within that system, nor does it assume liability for any consequential damage to general property or other components of the system.

Vaughn Thermal Corporation's Buffer Storage tanks have been designed to supply hot water when combined with a tankless coil boiler or other heat source.

Warning:

The Buffer Storage Tank is Not Hydrastone-lined and must be used in a closed loop system. This is not to be used for potable water. Potable water use will cause rapid corrosion and will void the warranty.

The design anticipates the proper installation and care in use of the product. There is risk of property damage and personal injury inherent in the use of any hot water system. The Company cannot supervise the installation and therefore makes it a specific condition of the warranty that the customer will supervise the installation and use of this product to be sure they are performed in with these instructions, as well as safe industry guidelines and proper local or national codes.

Generalized instructions and procedures cannot anticipate all situations. For this reason, only qualified installers should perform the installation. A qualified installer is a licensed person who has appropriate training and a working knowledge of the applicable codes, regulations, tools, equipment and methods necessary for safe installation of a boiler system and an indirect water heater.

An installation checklist has been provided to help the customer ensure that all procedures for a safe installation have been followed.

If questions regarding installation arise, check with your local plumbing and electrical inspectors for proper procedures and codes. Local codes take precedence over instructions in this manual. Local codes take a precedent over instructions in this manual. If you cannot obtain required information contact the Company.

INDEX

General information	Inside Front Cover
Installation Guidelines	2
Installation Checklist	4
Service Information	6
Maintenance	7
Typical Installation Diagram	8
Alternate Wiring Diagram	10
How to Obtain Assistance	11
Warranty	12
My model and serial numbers	Back Cover

To fully understand the purchaser's responsibility installing the water heater, please read the warranty.



P.O. Box 5431 • Salisbury, MA 01952-5431 • 978.462.6683

INSTALLATION GUIDELINES

A. LOCATION

- ❑ Place the heater on a solid foundation in a clean, dry location nearest the boiler.
- ❑ The heater should be protected from freezing and water lines insulated to reduce energy and water waste.
- ❑ Leave sufficient room to service the water heater and electrical controls.
- ❑ Do not install in an area where flammable liquids or combustible vapors are present.
- ❑ Do not install in close proximity of wood burning stove or other high temperature apparatus.

NOTE: If Heater is Placed On Blocks To Raise It From The Floor, Be **Sure** to Support The **Entire** Bottom With At Least $\frac{3}{4}$ " Plywood On The Top Of The Blocks.

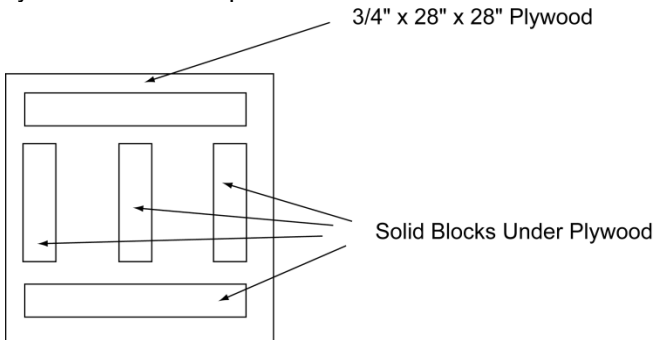

B. PROTECTION FROM WATER DAMAGE

- ❑ **CAUTION:** All water heaters have a risk of leakage at some unpredictable time. **IT IS THE CUSTOMER'S RESPONSIBILITY TO PROVIDE A CATCH PAN OR OTHER ADEQUATE MEANS, SO THAT THE RESULTANT FLOW OF WATER WILL NOT DAMAGE FURNISHINGS OR PROPERTY.**

The Warranty provided assures replacement within its terms, but specifically does not warrant against consequential damage caused by a leaking water heater.

C. RELIEF VALVE

- ❑ **WARNING: A POTENTIAL HAZARD TO LIFE AND PROPERTY MAY EXIST IN ANY WATER HEATER IF AN APPROVED TEMPERATURE-AND-PRESSURE RELIEF VALVE IS NOT PROPERLY INSTALLED.**
- ❑ For protection against excessive pressures and temperatures in this water heater, install temperature-and-pressure protective equipment by local codes, but not less than a combination temperature-and-pressure relief valve certified by a nationally recognized testing laboratory that maintains periodic inspection of production of listed equipment of materials, as meeting the requirements for Relief Valves and Automatic Gas Shutoff for Hot Water Supply Systems, ANSI Z21.22-1971. This valve must be marked with maximum set pressure not to exceed the marked maximum allowable working pressure of the water heater (150psi). Install the valve into an opening provided and marked for this purpose in the water heater, and orient it or provide the tubing so that any discharge from the valve will exit only within 6 inches above, or at any distance below the structural floor and cannot contact any live electrical parts. The discharge opening must not be blocked or reduced in size under any circumstances.
- ❑ **CAUTION: A relief valve is designed to discharge excessively hot water. THE CUSTOMER IS RESPONSIBLE TO PROTECT PROPERTY AND PERSONNEL FROM HARM WHEN THE VALVE FUNCTIONS.**
- ❑ A 3/4" NPT brass connection is provided on the side of the heater for the field installation of the relief valve. (See Figure 1).
- ❑ Care must be taken to be sure that the stem of the pressure-and-temperature relief valve is immersed in the water within the top 6 inches of the tank.
- ❑ The drain line must not be concealed or blocked and must be protected from freezing.

D. WATER SUPPLY CONNECTIONS

- ❑ **WARNING: Some local codes mandate the use of a backflow preventer or check valve or reducing valve. An adequate expansion tank (or other adequate means) must be installed to prevent pressure build up or damage from thermal expansion when a check valve or backflow preventer or reducing valve is used. Failure to do so could result in tank leakage and therefore void the warranty.**

E. FILLING THE HEATER

- ❑ Check that the temperature-and-pressure relief valve has been properly installed (mandatory requirement).
- ❑ Completely close the drain valve.
- ❑ Open the highest hot water faucet or outlet to allow air to escape from piping.
- ❑ Open the valve to the cold water inlet and allow the heater and piping system to completely fill, as indicated by a steady flow of water from the open faucet or outlet.
- ❑ Recommended to use a 1/2" Air Eliminator (Not Supplied)

INSTALLATION CHECKLIST

A. LOCATION

- Solid foundation and dry location.
- Protect heater water lines from freezing.
- Area free of flammable vapors.
- Sufficient room to service heater.
- Do not install in close proximity to wood burning stove or other high temperature apparatus.

B. PROTECTION FROM WATER DAMAGE

- Be sure to make provisions to protect area from water damage if a leak should occur in the tank or connected fittings.

C. RELIEF VALVE

- Warning: Improper installation will present potential hazard to life and property.**
- Check to be sure that proper relief valve requirements are met.
- Valve stem immersed in water within the top 6 inches of the tank.
- 3/4" discharge pipe – properly protected from freezing and restrictions.
- No valve between tank and relief valve or in drain line.
- Provision for hot water discharge from relief valve.

D. WATER SUPPLY CONNECTIONS (See Figure 1).

- Connect the boiler supply line to the combination return and drain valve. Do not apply heat directly to this combination fitting.
- Do not over tighten brass threads.
- If there is a check valve (sometimes in water meter), backflow preventer or reducing valve, install an adequate size expansion tank.**

E. FILLING THE HEATER

- Completely fill heater.
- Water connections completed and free of leaks.
- Check for proper installation of relief valve.
- Close drain valve.
- Open highest hot water faucet.
- Open cold water inlet valve and fill system.
- Recommended to use a 1/2" Air Eliminator (Not Supplied)

SERVICE INFORMATION

WATER TEMPERATURE REGULATION

WARNING: Exposure to 125° F or hotter water can cause scalding injuries. Appropriate caution must be taken when using hot water. Special supervision must be given to those who cannot act quickly such as children, invalids or elderly persons.

The input of heat into the tank is controlled by an immersion thermostat. These automatic controls are set at the factory to maintain a water temperature of 120° F*.

*Although these thermostats are designed to industry standards, they can fail to control temperature properly without any notice, and therefore should be tested periodically for your protection.

DANGER: IF YOU DISCOVER EXTREME HOT WATER COMING FROM THE FAUCET, IMMEDIATELY SHUT OFF THE MAIN SWITCH TO THE BOILER AND CALL COMPETENT SERVICE PERSONNEL. ANY OVERHEATED WATER IS A POTENTIAL HAZARD TO LIFE AND PROPERTY. DO NOT OPERATE UNTIL THE SOURCE OF THE PROBLEM HAS BEEN DETERMINED AND ELIMINATED.

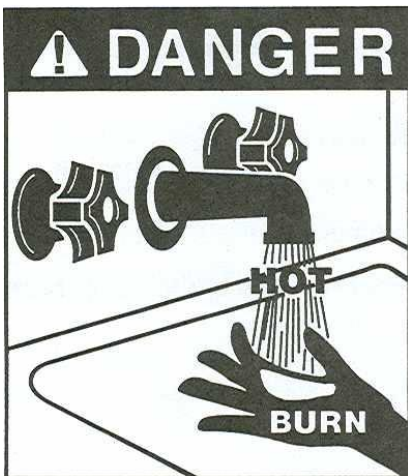

- Water temperature over 125° F can cause severe burns instantly or death from scalds.
- Children, disabled and elderly are at the highest risk of being scalded.
- See instruction manual before setting temperature at the water heater.
- Feel water before bathing or showering.

MAINTENANCE

WATER TEMPERATURE CONTROLS

A periodic inspection of the heating system should be made by qualified service personnel.

Temperature of the water should be tested periodically at the faucet to be sure thermostat is working properly.

EMERGENCY

Should the heater be subject to flood, fire or other damaging conditions, turn the power and water to the heater off. **DO NOT** place water heater in operation again until it has been thoroughly checked by qualified service personnel.

FIGURE 1

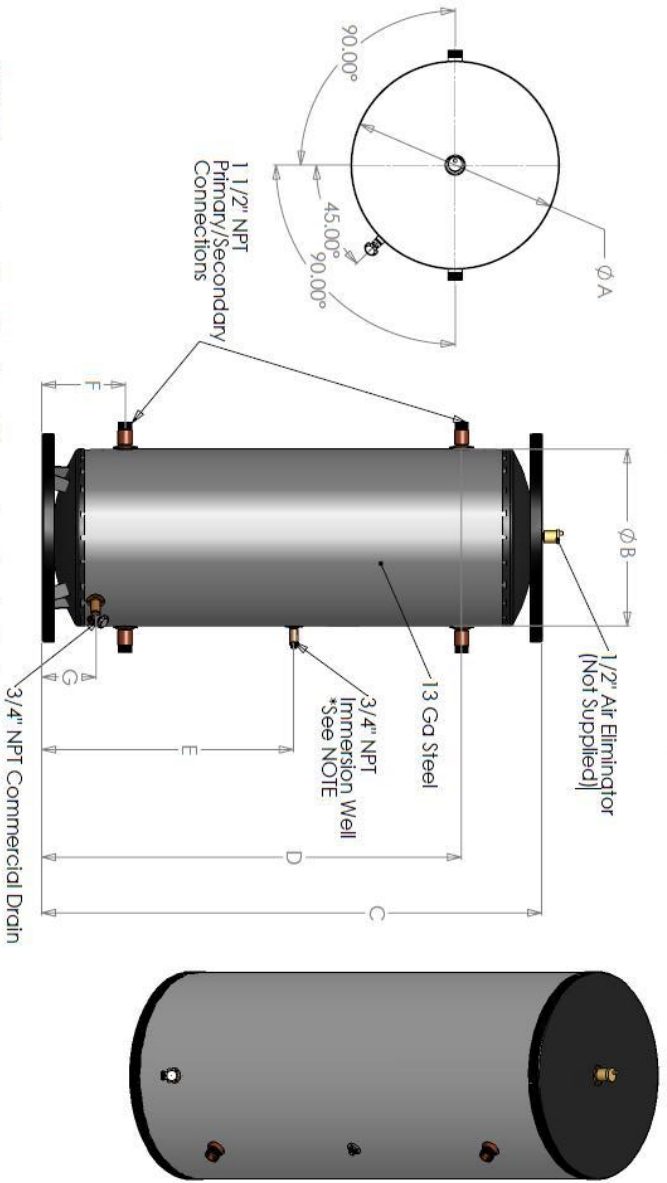

* NOTE: Immersion well on 10 gallon will be centered on the front of the tank.

	A	B	C	D	E	F	G
10 Gallon	20	16	21.5	13.5	11.125	8.0625	7.5
20 Gallon	20	16	32.75	25.25	17.125	9	7.5
30 Gallon	20	16	40.625	32.75	20.875	9	7.5
40 Gallon	20	16	56.25	48.5	28.75	9	7.5
50 Gallon	22.75	19	49.75	41	25	9.375	7.875
80 Gallon	26	22	57.25	48.25	28.75	9.375	7.875
100 Gallon	26	22	67.5	58.875	34.125	9.375	7.875
120 Gallon	28	24	67.75	58.875	34.125	9.375	7.875

HOW TO OBTAIN SERVICE ASSISTANCE

Should you have any questions about your new water heater concerning service adjustment, repair, or routine maintenance, **first contact your installer, plumbing contractor or service agency.**

In the event that the firm, for whatever reason, is unable to help, refer to the telephone directory commercial listings for qualified service assistance.

If neither action has solved your problem, contact Vaughn Thermal Corporation as follows:

**CUSTOMER RELATIONS DEPARTMENT
VAUGHN THERMAL CORPORATION
26 OLD ELM STREET
P.O BOX 5431
SALISBURY, MA 01952
Or call 978-462-6683**

When contacting Vaughn the following information should be made available:

- A. Model and serial number of the water heater as listed on the back of this manual or on the rating plate on the heater.**
- B. Address where water heater can be seen.**
- C. Name and address of dealer from whom the heater was purchased and installer's name and address.**
- D. Date of original installing and any service work performed sine then.**
- E. Details of the problem as you can best describe.**
- F. List of people who have been contacted regarding the problem.**

BUFFER STORAGE TANK

Three Year Limited Tank Replacement Policy One Year Limited Parts Warranty

Vaughn Thermal Corporation, (hereinafter called the company) offers the following Limited Tank Replacement Policy, and Limited Parts Warranty to the original purchaser/owner of this **Buffer Storage Tank**.

These warranties are not transferable beyond the original purchaser/owner, and are not valid if the tank is removed from initial installation site. THIS WARRANTY SPECIFICALLY EXCLUDES ANY IMPLIED WARRANTY OF MERCHANTABILITY OR OF FITNESS FOR ANY PARTICULAR PURPOSE, AS WELL AS ANY PERFORMANCE WARRANTY. The Company reserves the right to require proof of purchase as a condition of these warranties.

LIMITED TANK REPLACEMENT POLICY

DURATION: (3) years from the date of original purchase, or (3) years and 60 days from the date of manufacture – whichever comes sooner.

COVERAGE: Replacement policy covers only the storage tank for leaks caused by the corrosive effects of water under normal and proper use. Recovery under the terms of this agreement is subject to prior approval by the company. The tank replacement policy excludes any performance warranty or any warranty implied or specific of merchantability and fitness for its intended use.

COMPANY OBLIGATION: Repair of the original tank or replacement of the entire heater with a new comparable model is at the option of the company and constitutes the fulfillment of **ALL** obligations of the Company hereunder. In replacing or repairing the **Buffer Storage Tank**, the company reserves the right to make such changes in details of design, construction or material as shall in their judgment constitute an improvement of former practices.

REPLACEMENT: When a replacement is made under the terms of this policy, the replacement unit will have a policy of replacement only for the remaining time under the original policy. The Company reserves the right to require the return of the defective unit at the expense of the purchaser.

LIMITATION: All repairs or replacements will be made F.O.B. the company. The purchaser must pay for transportation service, labor, installation, administrative fees or other costs involving the repair or replacement of such part.

LIMITATION: All other repairs or replacements will be made F.O.B. the Company. The purchaser must pay for all transportation, service, labor, installation, administrative fees or other cost involving the repair of replacement of such component parts.

YOUR ACTION: When you discover a defect, immediately notify the dealer from whom the heater was purchased. If you cannot locate the dealer, contact the Company.

LIMITED PARTS WARRANTY

DURATION: The warranty is effective for (1) year beginning with the date of original purchase. At the time the claim is filed, if original purchaser cannot provide a copy of the original sales receipt, deed or equivalent document in the case of a new home purchase, this warranty shall begin from the date of manufacture as indicated by the serial number.

COVERAGE: The warranty covers any component part of the **Buffer Storage Tank** water heater proven to be defective in workmanship or material. Recovery under the terms of this agreement is subject to prior approval by the company.

COMPANY OBLIGATION: The warranty covers any component of the **Buffer Storage Tank** water heater proven to be defective in workmanship or material. Recovery under the terms of this agreement is subject to prior approval by the Company.

EXCLUSIONS AND LIMITATIONS

Limited Warranty and Tank Replacement Policy are valid only if you comply with the following conditions and limitations:

1. The **Buffer** must be correctly installed according to the installation manual provided with the unit and all applicable local and national codes.
2. The unit must be operated within the factory calibrated temperature limits and water pressure not exceeding 150 psi.
3. Any failure or malfunction that results from improper or negligent operation, accident, abuse (including freezing), misuse, unauthorized alteration or improper maintenance is specifically excluded.
4. Any failure or malfunction that results from failure to keep the tank full of potable water, free to circulate at all times; and free of damaging water sediment or scale deposits is specifically excluded. In areas where adverse water conditions are suspected (i.e. calcium and other minerals), it is essential that the water be tested and appropriate action be taken to prevent damage to the Buffer tank.
5. This Limited Warranty and Tank Replacement Policy specifically exclude any implied warranty of merchantability or of fitness for any particular purpose, as well as any performance warranty.

IN NO EVENT SHALL THE COMPANY BE LIABLE FOR ANY INCIDENTAL OR CONSEQUENTIAL DAMAGES WHATSOEVER.

Some states do not allow the exclusion or limitation of implied warranties or of liability for incidental or consequential damages, so the above limitation(s) or exclusion(s) may not apply to you.

SPECIFIC LIMITATIONS: If any provision or part of this warranty is declared invalid the remaining provisions (or parts thereof) shall remain in full force and effect. This is the only warranty for this heater made by the Company. It does not authorize Company representatives or other persons to vary the terms of this warranty or to assume for the Company any other obligations or liabilities with respect to this product.

**The following information should be noted
At time of installation and retained for
Future reference.**

Model No. _____

Serial No. _____

Date Installed _____

Dealer's Name _____

Address _____

City _____

State _____ Zip _____



26 Old Elm Street · P.O. Box 5431 · Salisbury, MA 01952-5431 · 978.462.6683